



Installation and Combination Changing Instructions

8500 Series MP Safe Locks

Models 8550 (Group 1) and 8560 (Group 1R)

- Für Anweisungen auf Deutsch besuchen Sie bitte die folgende Website:
- Para obtener instrucciones en español, visite la siguiente página web:
- Pour obtenir les instructions en français, veuillez consulter le site ci-dessous:
- Per istruzioni in lingua italiana, visitare il sito web seguente:
- 如果要获取中文版的说明, 请访问以下网址:

www.sargentandgreenleaf.com/OPinstr.php

NOTE: READ COMPLETE INSTRUCTIONS BEFORE INSTALLING, OPERATING, OR CHANGING THE COMBINATION OF THE LOCK

Caution: Lock mounting and dial ring mounting surfaces must be parallel. Dial ring center line must be precisely aligned with lock spindle center line (see illustration at right).

It is necessary to remove only the cover when attaching the lock. All other parts should remain in place as received from the factory.

INSTALLATION INSTRUCTIONS

1. Remove the lock cover. Place the lock bolt in the extended position and the accelerator spring in the loaded position (Figure 2).

CAUTION: Do not remove the drive cam. Do not stress the accelerator spring.

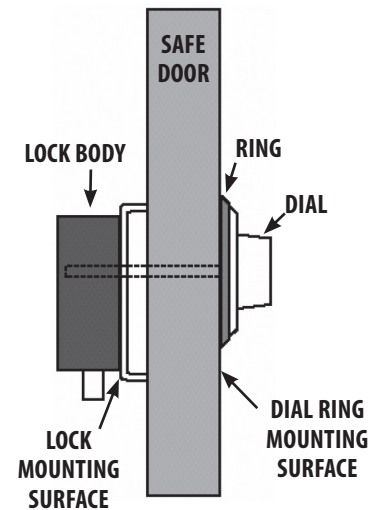
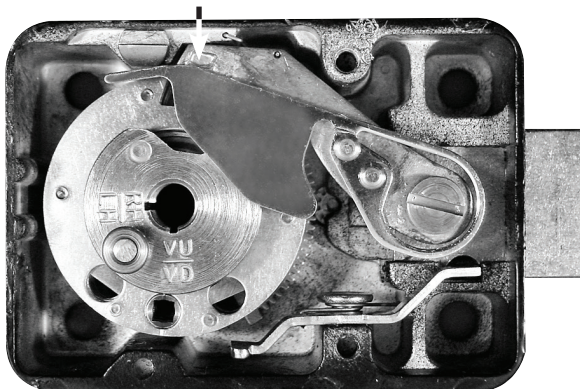

Figure 1

Accelerator Spring in Released Position



Accelerator Spring in Loaded Position

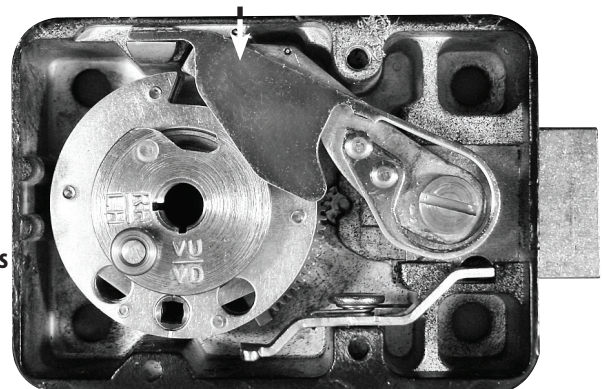

Figure 2
8500 Lock
Illustrations

Sargent & Greenleaf, Inc.
 A Wholly Owned Subsidiary of Stanley Security Solutions, Inc.
 PO Box 930
 Nicholasville, KY 40340-0930
 Phone: (800)-826-7652 Fax: (800)-634-4843
 Phone: (859)-885-9411 Fax: (859)-887-2057

Sargent & Greenleaf S.A.
 9, Chemin du Croset
 1024 Ecublens, Switzerland
 Phone: +41-21 694 34 00
 Fax: +41-21 694 34 09

2. Mount the lock body using four 1/4-20 or M6 attaching screws, whichever size is appropriate for the mounting surface provided by the safe manufacturer. Torque to 30 to 40 inch-pounds (3,39 to 4,52 Nm).

3. Install the dial ring bearing into the dial ring from the back side, and attach the dial ring to the container's mounting surface by loosely installing the 8-32 or M4 attaching screws to hold the dial ring in place for alignment. The dial ring opening index should be at the 12 o'clock center position (see Figure 3).

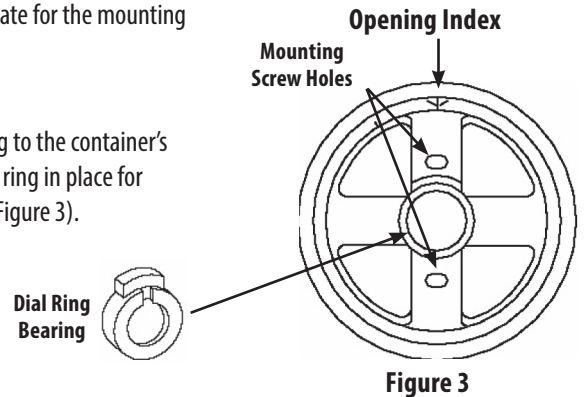

4. To install the dial, hold the drive cam in place with one hand and thread the dial/spindle assembly into the cam until the top surface of the dial's number band is nearly flush with the top of the rim that runs around the circumference of the dial ring (Figure 4).

Caution: When threading the dial into the cam, do not allow the cam to slide outward against the accelerator spring. The spring can be easily damaged in this manner.

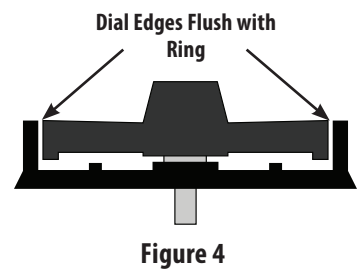

5. The alignment of the dial within its ring is critical to the proper operation of the lock (Figure 5). Perfect alignment must be obtained. The dial should be flush and centered with the surface of the dial ring for true centering. Make small adjustments in the position of the dial ring until the dial is precisely centered, then use masking tape or painter's tape to hold the dial ring in place.

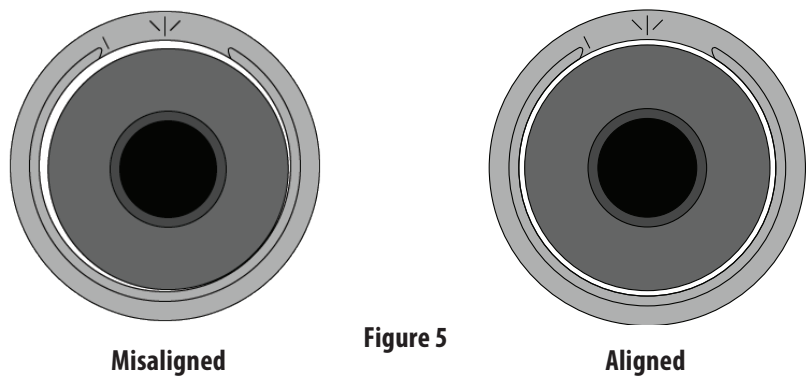

6. Measure the excess spindle that projects beyond the drive cam (Figure 6). Carefully remove the dial. Tighten the dial ring mounting screws. Cut off the excess spindle, and remove any burrs from the end. You may also find that the spindle threads more easily into the drive cam after cutting if the spindle end is beveled slightly.

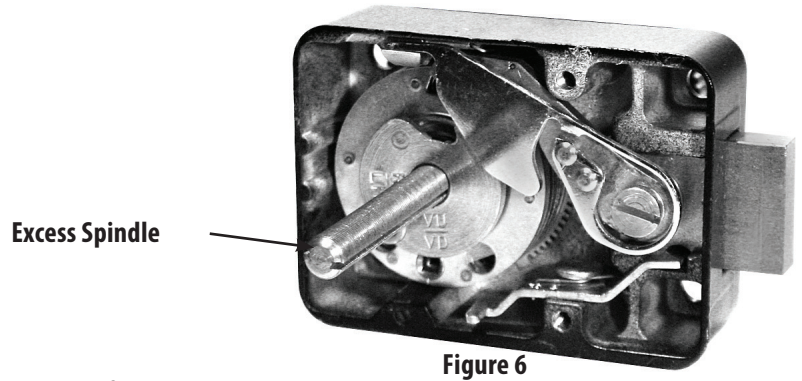

7. Place a flat washer, the compression spring, and another flat washer over the spindle and into the recess at the dial hub (Figure 7).

8. Insert the dial into the lock, but remember that you should not allow the cam to slide outward against the accelerator spring, possibly damaging it. Hold the drive cam in place, positioned for its gate to receive the nose of the drop lever, and thread the dial into the cam until the top surface of the dial's number band is nearly flush with the top of the rim that runs around the circumference of the dial ring (just like you did in Step 4).

9. Turn the dial counterclockwise until zero is aligned with the opening index of the dial ring. When this is done, the proper spindle spline keyway and drive cam spline keyway should be closely aligned (vertical-up—VU, right-hand—RH, etc.). Use Figure 8 to help determine the hand of mount for your lock.

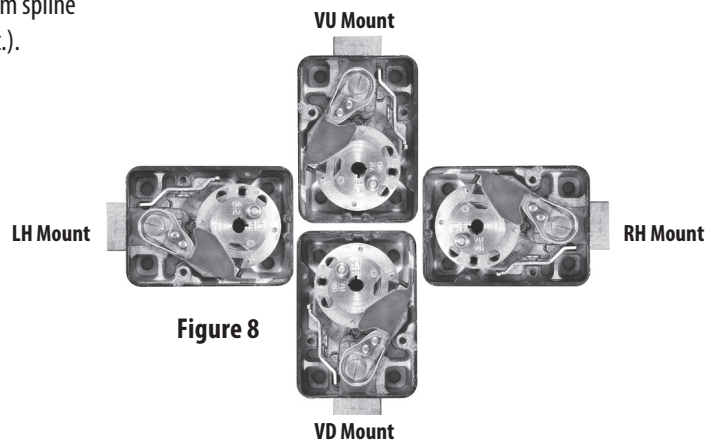

10. Insert the spline key with the tip toward the edge of the cam. Tap in lightly. Be very careful to avoid striking the stainless steel roller that is attached to the top surface of the drive cam. With the spline key inserted fully, the dial must turn freely with no rubbing or interference.

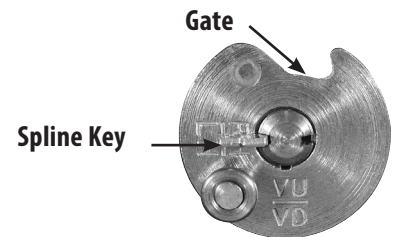

Note: Before installing the lock's cover, check for proper in and out travel of the dial to make sure the accelerator spring operates correctly.

11. Turn the dial at least one complete revolution in either direction and then stop at zero. The accelerator spring should now be in the loaded position.

12. Hold the cover in place on the lock and push the dial in at zero. Release the dial. Remove the cover and check the position of the accelerator spring. It should be in the released position. If the accelerator spring is not in the released position, the dial has not been backed out of the cam far enough, and the condition must be corrected. Remove the spline key, hold the cam, and rotate the dial one additional full turn counterclockwise. Install a new spline key and re-install the dial. Repeat checking and adjusting until the accelerator spring loads and releases as it should with the lock cover held in place.

13. Turn the dial at least one complete revolution in either direction, then stop at 50. The accelerator spring should now be in the loaded position.

14. Turn the dial at least one complete revolution in either direction, then stop at 50. The accelerator spring should now be in the loaded position.

15. Hold the lock cover in place and push the dial in at 50. The accelerator spring should not release. If the accelerator spring does release, the spindle must be turned clockwise into the cam one revolution and the lock checked again, beginning at step 11.

16. Dial the factory combination (4 times left to 50, right to 0, push in, let the dial out, turn right until the dial comes to a stop at about 85) and observe the drop lever falling into the drive cam. Repeat this step at least three times, checking to make sure the drop lever falls into the drive cam gate each time.
17. When the accelerator spring is operating properly, the cover may be attached to the lock. Do not lock the safe or cabinet until the lock has been checked for proper operation at least three times with the door OPEN.
18. Follow instructions below to change the combination from the factory setting. The combination must be reset before putting the lock into operation.

DIALING THE COMBINATION TO OPEN THE LOCK

Before operating the lock or changing the combination, read these instructions thoroughly.

On the dial ring are two index marks (Figure 10). The one at the top is for normal dialing and opening. The index to the left is provided for use only when changing the combination.

Turn the dial slowly and steadily. If, after turning the correct number of revolutions, any number is turned beyond the index mark, the entire series of combination numbers must be re-dialed. You cannot back up to a number if you pass it when you meant to stop on it. Each time a selected number is aligned with the opening index, it counts as one revolution, even if you only have to turn the dial a few numbers to achieve the initial alignment.

CAUTION: The dial should not be pushed in until the combination has been dialed and the dial returned to zero at the opening index.

TO UNLOCK ON A FACTORY COMBINATION OF 50

1. Turn the dial counterclockwise (left) at least four complete revolutions, then stop when 50 is aligned with the opening index.
2. Turn the dial clockwise (right), stopping when 0 is aligned with the opening index the first time.
3. With 0 aligned at the opening index, push the dial in firmly to activate the lever assembly, then release it.
CAUTION: The dial should not be pushed in until 0 is aligned with the opening index.

4. Turn the dial right until the bolt retracts. The dial should come to a positive stop at about 85. If the combination has been correctly dialed, the safe or cabinet may be opened.

TO UNLOCK ON A THREE NUMBER COMBINATION

1. Starting anywhere, turn the dial left (counterclockwise), stopping when the first combination number comes to the opening index the FOURTH time.
2. Turn the dial right (clockwise), stopping when the second number comes to the opening index the THIRD time.
3. Turn the dial left, stopping when the third number comes to the opening index the SECOND time.
4. Turn the dial clockwise (right), stopping when 0 is aligned with the opening index the first time.
5. With 0 aligned at the opening index, push the dial in firmly to activate the lever assembly, then release it. **CAUTION:** The dial should not be pushed in until 0 is aligned with the opening index.
6. Turn the dial slowly to the right until it comes to a positive stop, indicating the lock bolt has retracted.

TO LOCK

Turn the dial counterclockwise (left) at least five complete revolutions for maximum security.

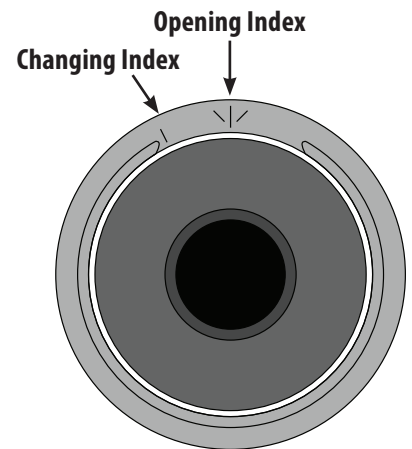

Figure 10

CHANGING THE COMBINATION

Make up a new combination, selecting three numbers of your own choosing. Do not set the third number of the combination between 90 and 99 or 0 and 10. This area is known as the forbidden zone. Adjacent combination numbers should be at least 5 numbers apart. Numbers that end with 0 or 5 should not be used for all combination numbers. Do not use strictly ascending (ex. 22-45-83) or descending (ex. 83-45-22) combination sequences. Also, do not use numbers someone could easily guess.

Caution: Only use S&G change key U8 or U9 on the 8500 series lock. Other keys will not function properly and may damage the lock.

Note: If your lock is set on the factory combination of 50, turn the dial left (counterclockwise) at least four complete revolutions, then stop when 50 is aligned with the changing index, then skip to Step 4 for insertion of the change key into the lock. If your lock currently has a three-number combination, start with Step 1 below.

1. Starting anywhere, turn the dial left (counterclockwise), stopping when the first combination number comes to the CHANGING index the FOURTH time.
2. Turn the dial right (clockwise), stopping when the second number comes to the CHANGING index the THIRD time.
3. Turn the dial left, stopping when the third number comes to the CHANGING index the SECOND time.
4. With the third number at the CHANGING index, insert the change key into the hole in the lock cover (Figure A) until the wing is entirely inside the lock case, and the key comes to a positive stop.

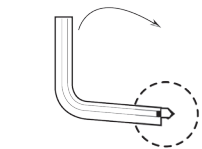
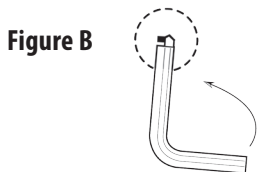
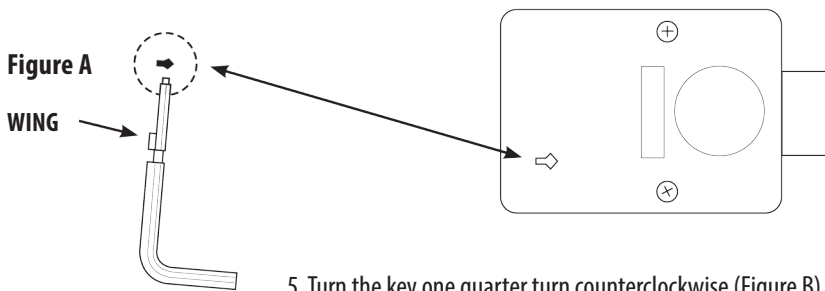

5. Turn the key one quarter turn counterclockwise (Figure B). With the change key in this position, turn the dial left (counterclockwise), stopping when the first new combination number aligns with the CHANGING index the FOURTH time.
6. Turn the dial right (clockwise), stopping when the second new combination number aligns with the CHANGING index the THIRD time.
7. Turn the dial left, stopping when the third new combination number aligns with the CHANGING index the SECOND time.
8. Turn the dial right 10 numbers. Turn the change key clockwise a quarter turn and remove it (Figure C). Your new combination should now be installed in the lock.

Important: After changing the combination, the lock should be opened and locked several times (by dialing to the opening index) WITH THE SAFE DOOR OPEN.

Warning: Never insert the change key into the lock when the cover is removed. Always be certain the wing of the change key is entirely within the lock (Figure B) before turning the key.

Sargent & Greenleaf 8500 Series Mechanical Safe Lock Specifications

Attaching Screws: Use only the screws provided with the lock. Screws will be ¼-20 or M6, depending on the application. They must engage the mounting plate by at least four full threads. Do not use lock washers or thread sealing compounds unless specifically directed to do so in the full installation instructions.

Recommended Attaching Screw Torque: 30 to 40 inch-pounds (3,39 to 4,52 Nm) for the lock body. No more than 15 inch-pounds (1,695 Nm) for the dial ring attaching screws.

Minimum Spindle Hole Diameter: 0.375 inch (9,5 mm) round opening

Maximum Spindle Hole Diameter: 0.5 inch (12,7 mm) round opening

Lock is Designed to Move: 0 lbs. (0 Newtons) continuous or maximum

Lock Bolt Maximum Free Movement: 0.461 inch (11.7 mm). At least 0.109 inch (2,77 mm) of the lock bolt remains outside the edge of the lock case when bolt is fully retracted.

Maximum Bolt End Pressure: The lock is designed to withstand at least 225 lbs. (1000 Newtons)

Maximum Bolt Side Pressure: The safe and container boltwork or locking cam designs must never apply more than 225 lbs. (1000 Newtons) of side pressure on the lock bolt.

Mounting Environment: The lock body is designed to be mounted inside a secure container. The container must be constructed to offer protection against physical attack directed at the lock. The amount of protection is dependent on the desired level of security for the system as a whole. Lock protection may include barrier materials, relock devices, thermal barriers, thermal relock components, or any combination of these. Relock device attaching screws must **NOT** be longer than the depth of the tapped attaching screw hole provided in the lock case. A minimum distance of .150 inch (3,8 mm) is recommended between the end of the lock case and the closest approach of the safe's blocking bar or cam plate (which is normally blocked by the extended lock bolt). Maintaining this clearance will allow the lock to deliver optimum performance. The container should be constructed to prevent access to the combination lock without the use of tools when the container door or drawer is left open.

Handing and Spling: The lock is designed to be mounted right-hand, left-hand, vertical-up, and vertical-down only. The dial spindle and lock drive cam must be aligned for the hand of mount dictated by the application and connected to each other in this alignment by use of an included friction-fit spline key.

Combination Restrictions: Personal data that can be related to a code holder, such as a birth date, street number, or phone number, should not be used in creating a lock code. Avoid codes that can be easily guessed.

Note: Every installation of this product must comply with these requirements and those in the product installation instructions to qualify for the manufacturer's warranty and to comply with EN1300 requirements.

DIMENSIONS—8500 SERIES MECHANICAL LOCK CASE

