

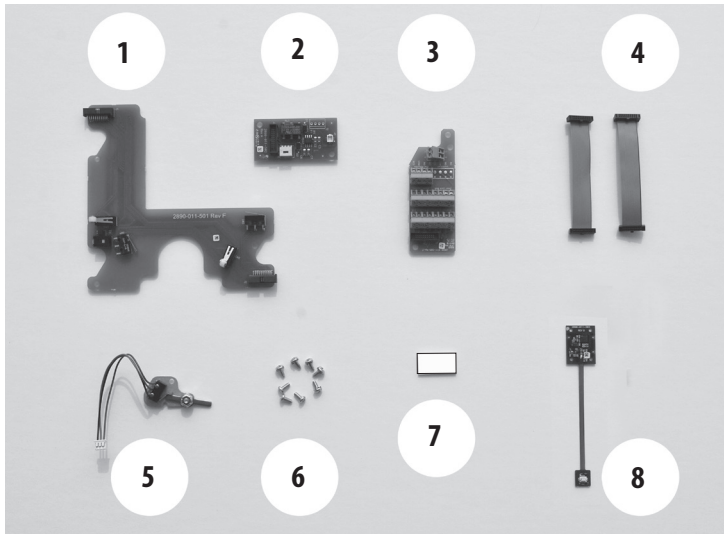

Installation Instructions for: Model 2890B Alarm Kit

Introduction

Congratulations on your purchase of the 2890B alarm kit package. This Installation Manual explains how to install the kit during a lock installation. Some disassembly is required to install this kit in an existing lock.



1. Component Identification and Description (BOM Chart)

Item	Description	Req'd
1	CENTER PCB ASSEMBLY	1
2	COMBINATION LOCK PCB ASSEMBLY	1
3	TERMINAL BLOCK PCB ASSEMBLY	1
4	CABLE	2
5	COMBINATION BOLT POSITION SWITCH	1
6	INSTALLATION HARDWARE	8
7	TAPE, DOUBLE SIDED 1/16" X 1/2" X 6"	1
8	DIAL ROTATION SENSOR	1

If you are starting with a 2890B that has already been installed, follow the directions below. If installing a new lock, skip to Step 11 on the back of this sheet.

1. Work from the portion of the lock that is on the interior of the room.



2. Make sure the cam lock is in the horizontal position. Remove the two fasteners from the side of the center module, on the side opposite the bolt.



3. Remove the four fasteners on the front of the center module cover.

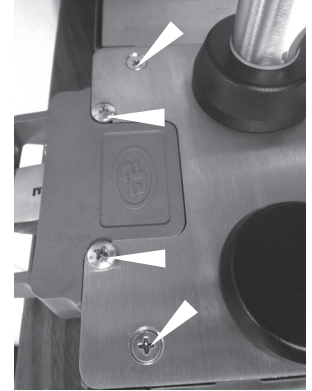

4. Now the cover handle assembly should lift off.

5. Remove the two flathead screws to allow the top cover to come off. Remove the two flathead screws to allow the bottom cover to come off.

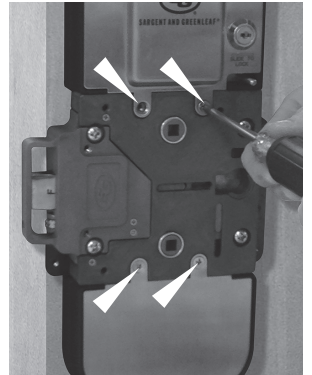

6. Remove the four mounting screws that are holding the lock to the door. (These are located in the four inside corners of the interior assembly).

7. Next remove the high security combination lock from the top of the lock. The specific steps of the lock removal will depend upon whether the lock is a SG 2740 (shown) or a KABA X-10

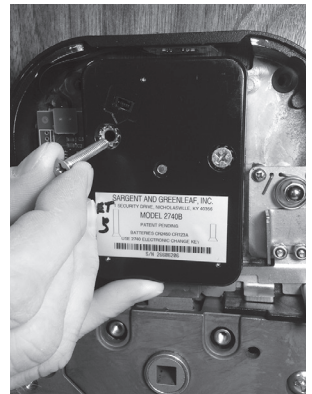
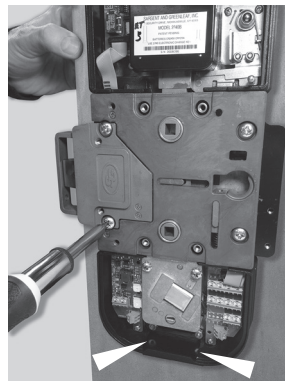

8. Next remove the four large bolts holding the module to the mounting plate & 4 screws.

9. Save the spindle and put it back in the door for safe keeping. The access control module can remain in the lower module. Care must be taken to ensure proper insertion of the cylinder tab when you remount the module.

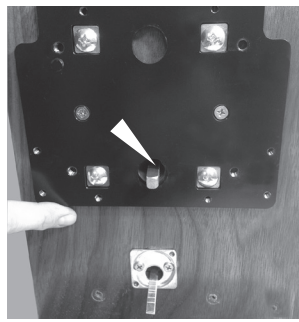
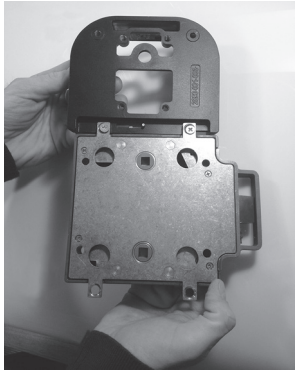

10. Remove the upper housing by removing the 2 fasteners. Remove the lower housing by removing the 2 fasteners.

If Installing the 2890B Alarm Kit as a New Install, See Below:

11. Install Combination Lock PCB into Lock Housing

Insure that the wide connector is positioned toward the bottom of the housing and secure the PCB with (2) #4 machine screws.

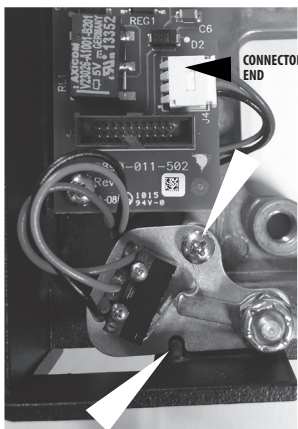
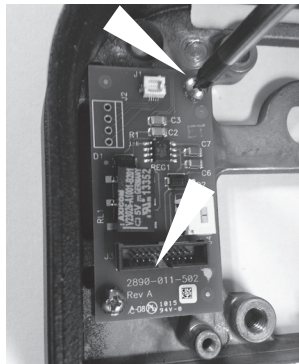

12. Install Combination Bolt Position Switch

While routing connector end of the cable under the Combination Lock PCB, position switch assembly as shown while ensuring that the notch at the bottom of the plate aligns with the notch on the housing surface and secure with (1) #4 machine screw. Insert the connector into the white receptacle on the PCB. NOTE: The **short end** of the lever must point toward the switch and must rotate freely.

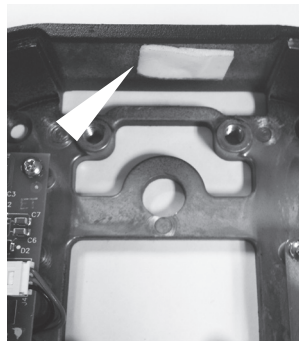

13. Install Dial Rotation Sensor

Remove film from one side of the included 2-sided foam tape and apply it to the center of the rectangular recess at the top of the combination lock housing.

Remove the remaining film and press the Dial Rotation Sensor directly to the tape keeping the sensor centered in the recess with the brown flex cable exiting to the left.

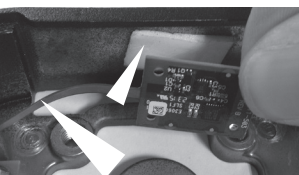

13. Install Dial Rotation Sensor (Cont.)

Plug the brown flex cable into the connector at the top of the Combination Lock PCB, taking care that the cable is clear of being pinched by later installation of the lock and the lock cover.

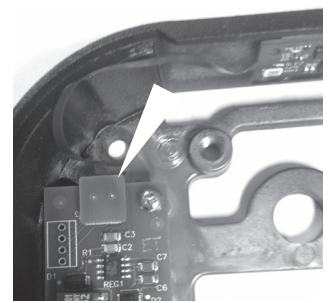
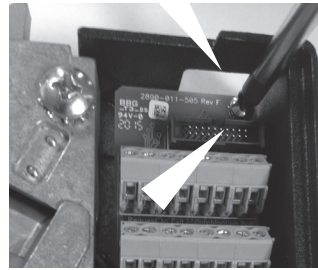

14. Install Terminal Block PCB

Orient Terminal Block PCB as shown and secure with (2) #4 self tapping screws.

15. Connect Cables to Center Module PCB

Locate the two 20 pin connectors on the larger Center Module PCB. The two cables are identical and can be connected to either connector. Align the square tab on the cable end with the notch on the connector and insert firmly.

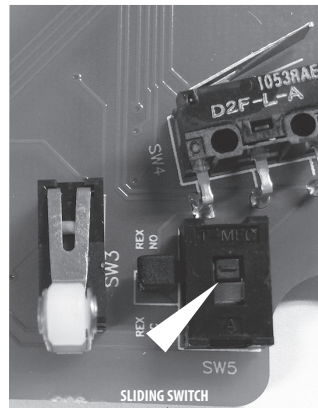
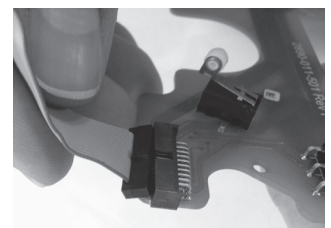
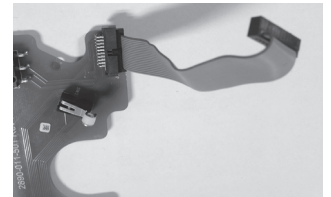

16. Check Center Module PCB Tamper Switch Setting

There are two choices for the lock tamper switch normally open (NO) or normally closed (NC). This is set with a sliding switch on the Center Module PCB. Make a note of the selected mode. You will need this information when wiring the lock unit to an external monitoring system.

17. Install the Center Module PCB and Cable into the Mechanical Assembly

Remove (4) screws from the mechanical assembly cover, lift off cover and set cover and screws aside.

Orient the mechanical assembly and the Center Module PCB as pictured and guide the two cables out through the two square holes in the mechanical assembly.

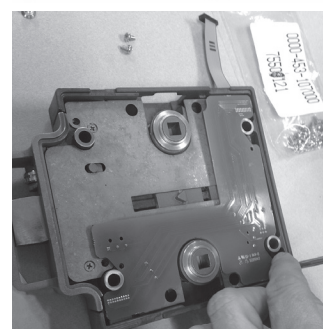
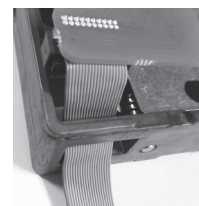
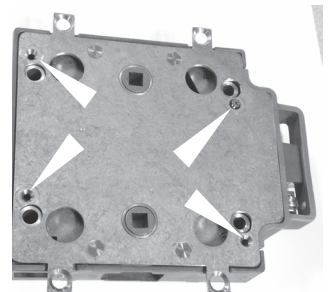

17. Install the Center Module PCB and Cable into the Mechanical Assembly (cont.)

Gently lower the PCB onto the mechanical assembly insuring that the switches fit into the voids, if any resistance is felt then the orientation of the PCB may be incorrect. Use the #4-40 screws to secure board to the mechanical assembly in three locations.

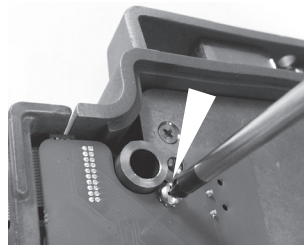

Correct switch roller position

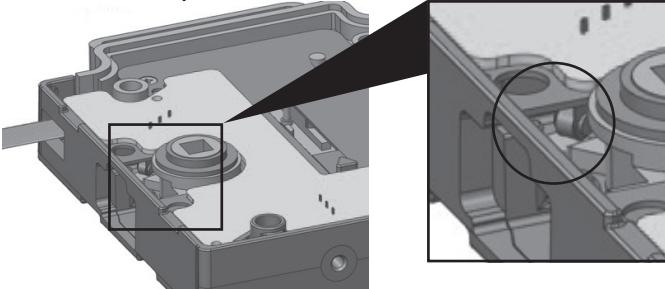

Incorrect switch roller position

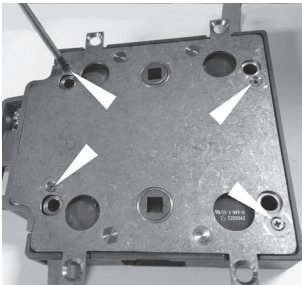
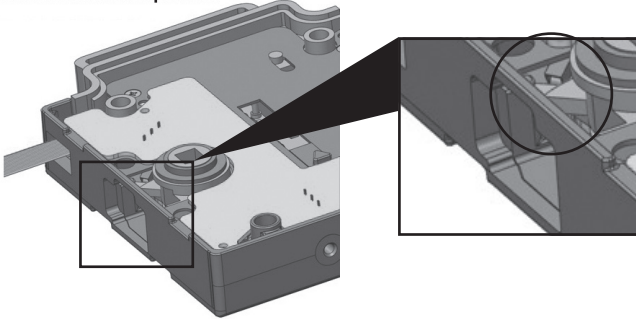

18. Secure Center Module PCB Assembly and Reinstall Cover

Secure the Center Module PCB Assembly using (3) #4 self-tapping screws. These screws contain a small star washer and cannot be interchanged with the cover screws. Reattach cover with (4) flathead screws previously removed.

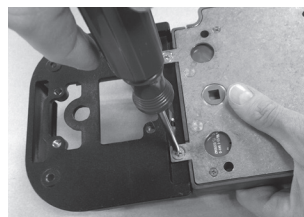
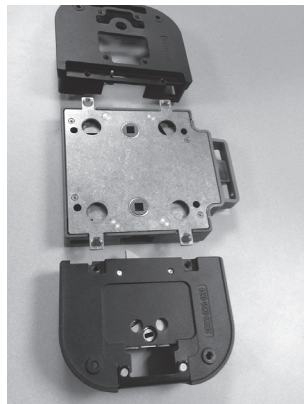

19. Assemble Lock and Access Control Housings to the Mechanical Assembly PCB

Position the three housings as they will be installed on the door.

After guiding the two 20 pin cables through the channels mechanically fasten the upper and lower modules to the center module.

19. Assemble Lock and Access Control Housings to the Mechanical Assembly PCB (cont)

With the cable installed, flip the unit over and connect the housings together. The PCB mechanical assembly is connected by cables. It is best to attach the upper module first and once it is secure, proceed to the lower module.

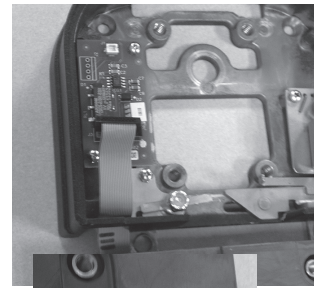
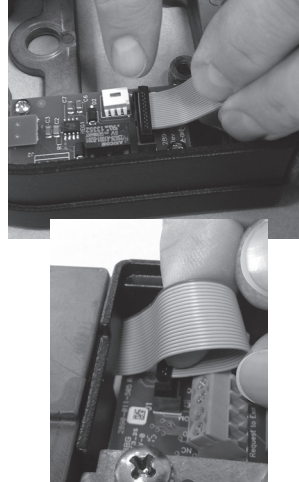

20. Connect Cables

Once the cable end is inside the housings it will align closely with the appropriate connector on the access control and combination lock PCBs. Align the tab on the cable end with the slot on the connector and press firmly.

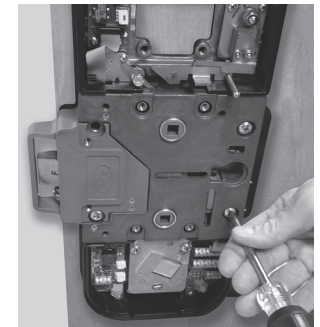

21. Mounting Exterior Assembly to the door

Now you are ready to mount the interior assembly to the door.

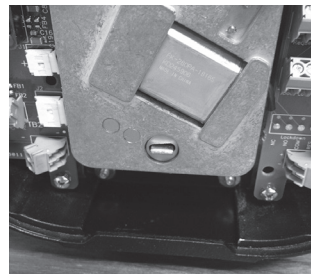

22. Properly Re-installing in the door

Please note, that you already have the access control module in place.

Align the handle spindle and the cylinder tab so that they properly insert in the interior assembly.

Reinstall the bolts that fasten the center module to the door.

21. Connect External System Wires to the Terminal PCB

Each lock sensor has four connection points: Normally open (NO), Normally closed (NC), common (COM) and resistor (RES). Six wiring options are provided to the right to be selected depending on the desired sensor response and wire tamper monitoring. To enable the dial rotation function operating voltage must be supplied to the Terminal PCB.

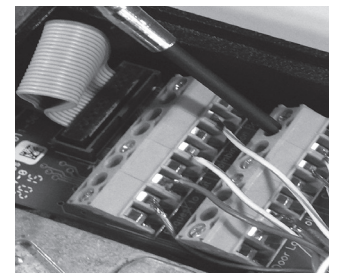
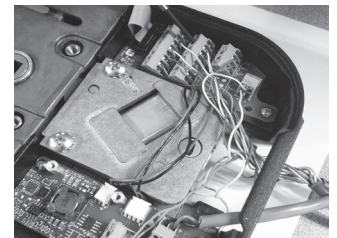

Alarm Panel Wiring Options

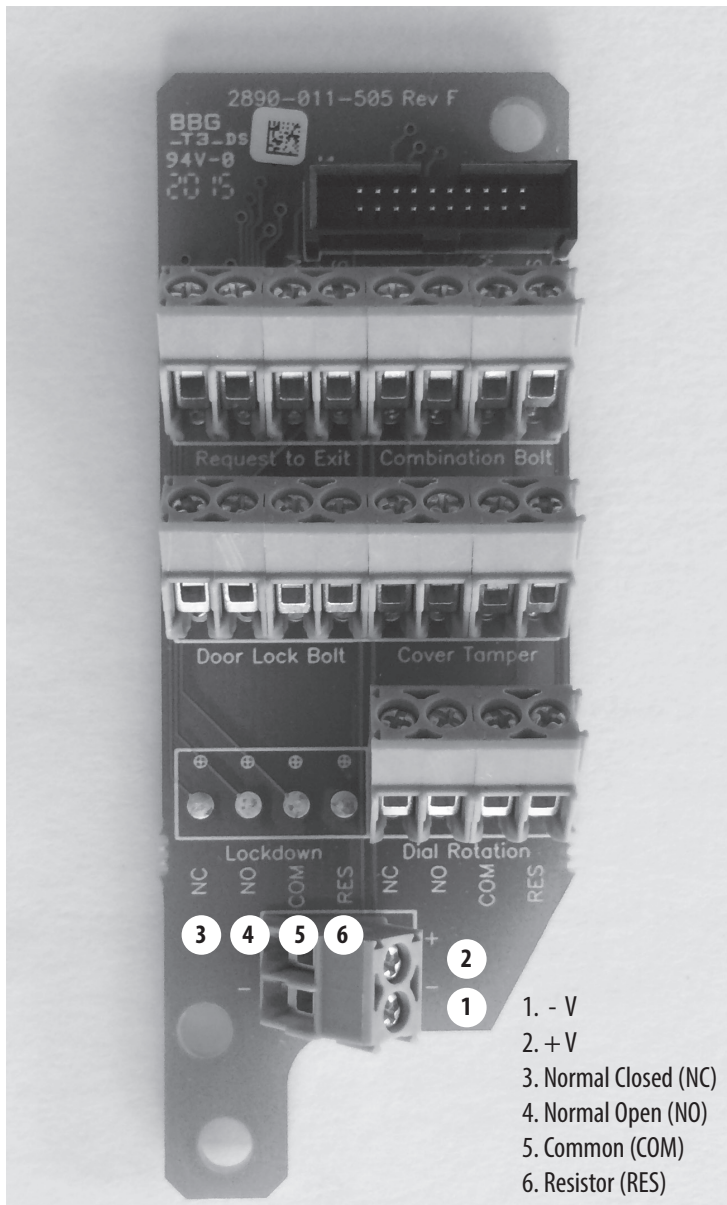
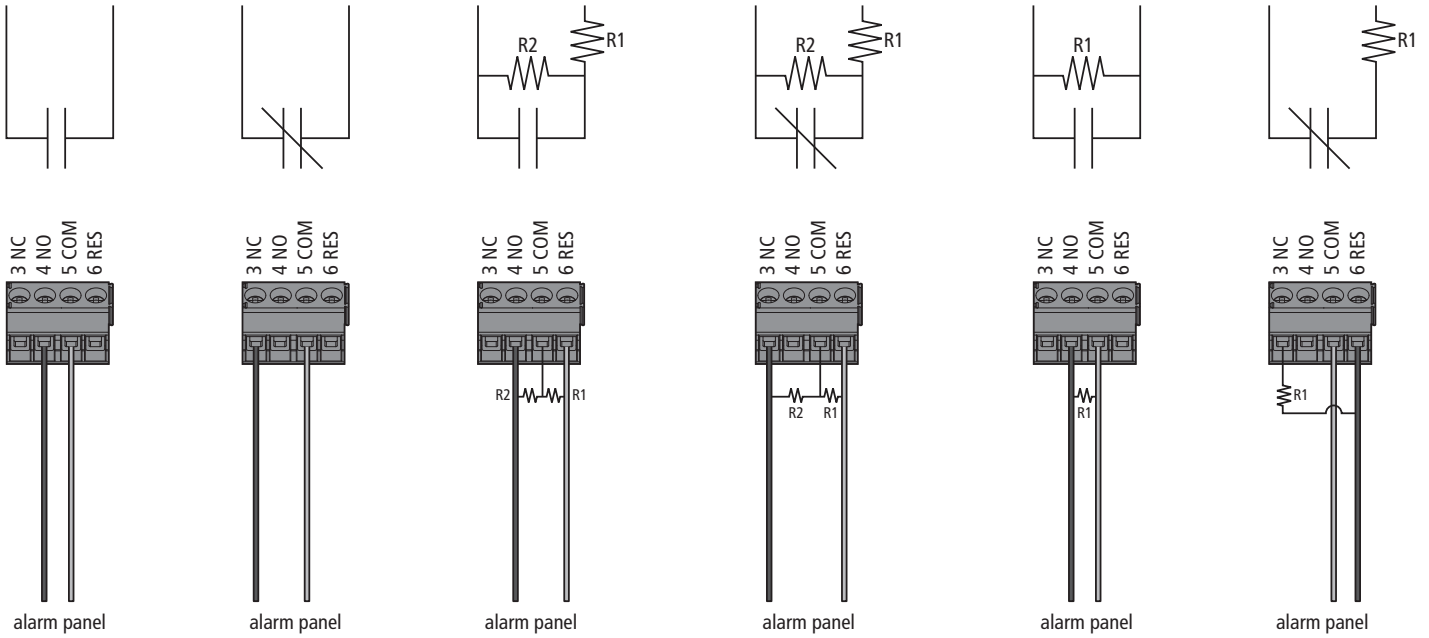

Inrush current : less than 500mA @ 12V, less than 300mA @ 24V

Holding Current: 250mA @ 12V, 170mA @ 24V

Requirements

Operating Voltage 12-24 VDC

Conductors 18-22 AWG

CONFIDENTIAL -The information contained in this document is proprietary to Sargent & Greenleaf, Inc. Publication or duplication of this copyrighted document is strictly prohibited.

S&G Audit Lock Electronic Safe Lock Limited Warranty
Sargent & Greenleaf, Inc.
A Wholly Owned Subsidiary of Stanley Security Solutions, Inc.
PO Box 930

Nicholasville, KY 40356
Phone: (800)-826-7652 Fax: (800)-634-4843
Phone: (859)-885-9411 Fax: (859)-887-2057
Sargent & Greenleaf S.A.
9, Chemin du Croset
1024 Ecublens, Switzerland
Phone: +41-21 694 34 00
Fax: +41-21 694 34 09