

Installation Instructions

Model 6128 A-Series Electronic Safe Lock



SARGENT AND GREENLEAF®

- Für Anweisungen auf Deutsch besuchen Sie bitte die folgende Website:
- Para obtener instrucciones en español, visite la siguiente página web:
- Pour obtenir les instructions en français, veuillez consulter le site ci-dessous:
- Per istruzioni in lingua italiana, visitare il sito web seguente:
- For instructions on the Chinese version, please visit the following URL:



Mounting Considerations

- Sargent & Greenleaf 6100 series Motorized Electronic Combination Locks have been designed to use the same mounting screw locations and occupy the same space as most other S&G locks, both mechanical and electronic.
- Modifications to the lock (including lock bolt attachments) are not recommended, and will void the your warranty.
- A minimum distance of .150" (3,8 mm) is required between the end of the lock case and the closest approach of the safe's blocking bar or cam plate which is normally blocked by the extended lock bolt. Do not allow the safe's blocking bar or cam plate to depress the electronic lock's bolt farther than it retracts during normal motor operation. This can lead to inconsistent lock operation.
- The 6100 series requires two 9-volt alkaline batteries (may or may not be included with your lock depending on the specific kit ordered). We recommend Duracell® batteries. Do not use old or partially drained batteries.

Attaching Screws: Use only the screws provided with the lock. Lock body mounting screws will be either ¼-20 or M6, depending on the application. They must engage the mounting plate by at least four full threads. Do not use lock washers or thread sealing compounds unless specifically directed to do so in the full installation instructions

Recommended Attaching Screw Torque: 30 to 40 inch-pounds (3.4 to 4.5 Nm) for the lock body. No more than 15 inch-pounds (1.695 Nm) for the keypad attaching screws.

Minimum Lock Cable (Spindle) Hole Diameter: 0.312" (7,9 mm) Maximum Lock Cable (Spindle) Hole Diameter: 0.406" (10,3 mm) Lock is Designed to Move: 0.0 lbs. (0 Newtons)

Lock Bolt Maximum Free Movement: 0.352" (8,95 mm) At least 0.109" (2,77 mm) of the lock bolt remains outside the edge of the lock case when bolt is fully retracted.

Maximum Bolt End Pressure: Lock is designed to withstand at least 225 lbs. (1000 Newtons)

Maximum Bolt Side Pressure: Safe and container boltwork or locking cam designs must never apply more than 225 lbs. (1000 Newtons) of side pressure on the lock bolt.

Interface with Boltwork: This lock is not intended for direct boltwork attachment. Before installing the lock, operate the safe opening mechanism and verify that the installed position will effectively secure the boltworks when the lock is locked. After installation, check that there is clearance between the combination lock bolt and the boltworks; as pressure on the bolt could affect the lock's ability to function properly.

Mounting Environment: The lock body is designed to be mounted inside a secure container. The container must be constructed to offer protection against physical attack directed at the lock. The amount of protection is dependent on the desired level of security for the system as a whole. Lock protection may include barrier materials, relock devices, thermal barriers, thermal these. Relock device attaching screws must NOT be longer than the depth of the tapped attaching screw hole provided in the lock case. A minimum distance of .150 inch (3,8 mm) is recommended between the end of the lock case and the closest approach of the safe's blocking bar or cam plate (which is normally blocked by the extended lock bolt). Maintaining this clearance will allow the lock to deliver optimum performance. The container should be constructed to prevent access to the combination lock without the use of tools when the container door or drawer is left open.

Code Restrictions: Personal data that can be related to a code holder, such as a birth date, street number, or phone number, should not be used in creating a lock code. Avoid codes that can be easily guessed.

Note: Every installation of this product must comply with these requirements and those in the product installation instructions to qualify for the manufacturer's warranty and to comply with EN1300 requirements.

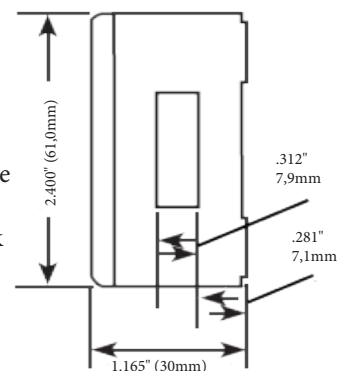
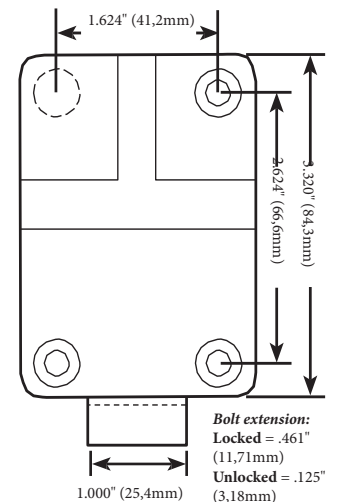

Before You Install

Your 6128 A-Series Lock was most likely shipped with the keypad and keypad extension connected to the lock cables to allow for pre-installation testing. If your lock does not have cables already connected to the keypad and keypad extension, temporarily connect them now as shown in these instructions. You should install fresh batteries in the keypad (S&G recommends Duracell® alkaline batteries) and check the function of the lock prior to installation by pressing 10101010# and observing the lock bolt retract, then extend 6 seconds later. After this check, disconnect the cables from the extension base and keypad by pulling on the connectors (NOT on the cables themselves). The installer should wear a properly grounded ESD wrist strap while working with lock cables and components to avoid ESD damage.

1. Remove the existing lock (if present). The mounting plate should be smooth and flat, with ¼-20 (M6) mounting screw holes. The wire channel (spindle hole) must have a diameter of at least 0.312 inch (7,9 mm). The 6100 series can be mounted right-hand, left-hand, vertical-up, or vertical-down without any modifications or adjustments.



2. Use a reamer or round file to remove any sharp edges from the wire channel (spindle hole) that might damage the wire cable. Gently pull the connectors to ease the cables through the hole. Pull 6" to 8" (15 to 20 cm) of cable to the front of the safe door. Later in the installation, excess keypad extension cable will be pulled back inside the safe door. Make sure cables are not crimped or stressed at any point.

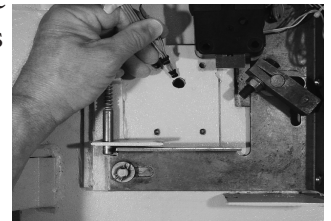

3. Using two of the ¼-20 (or M6) screws in the kit, loosely attach the lock body to the safe's mounting plate. This is just to hold it in place during cable attachments to the keypad and keypad extension. Be very careful to avoid crushing or crimping the cables. Note the black/red/green wire bundle. This is for the bolt position indicator, a dry contact switch (200 VDC, 0.5 amp max.) The black wire is common, the green wire completes a circuit to the black wire when the lock bolt is retracted, and the red wire completes a circuit to the black wire when the lock bolt is extended. The BPI can be used to trigger any switch-activated device.

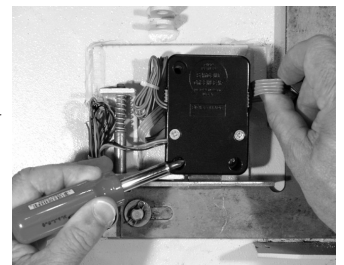

Note the blue wire loop. This is the secure loop, a closed circuit that may be used in applications requiring switches or other devices to signal the lock that boltwork is thrown, the door is closed, or some other action has taken place. The lock bolt will NOT retract if the circuit formed by the blue wire loop is open. Both sets of wires should be bundled and placed where they will not interfere with moving boltwork components if not used.

4. Remove the lock mounting screws so you can carefully pull the excess extension base cable inside. It is important to make sure the keypad and extension cables are within the recessed channels underneath the lock case before the case is securely attached by the three mounting screws. Once placed in the most convenient channel, each cable should be protected underneath the case by a self-adhesive foam or vinyl pad. It is very important that cables are not folded, crimped, or crushed beneath the lock case. There are four sets of wires that must be carefully placed where they will not interfere with or be damaged by moving boltwork. These are:

- excess keypad cable (4-conductor)
- secure loop (1-conductor blue wire)
- bolt position indicator (BPI) wires
- excess keypad extension cable (5-conductor) 2

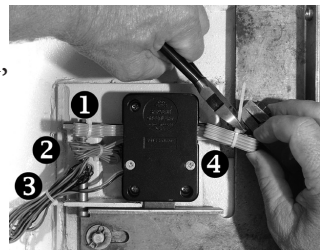

Lock installation Considerations

- A. Make sure the lock bolt doesn't bind against the safe's boltwork. The top photo shows binding of the edge of the cutout in the safe's blocking bar, even though the boltwork is fully thrown to the locked position. In the bottom photo, the binding has been relieved by removing a small amount of material from the side of the blocking bar cutout. It is important that there is clearance on all sides of the lock's bolt when the boltwork is in the fully locked position. Binding will impair the lock's performance. Any necessary modifications should be made to the boltwork, not the lock.

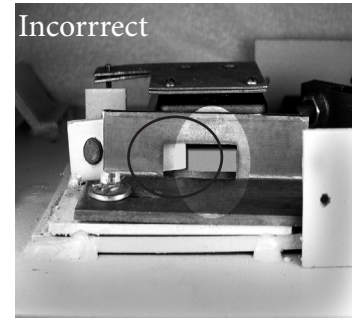
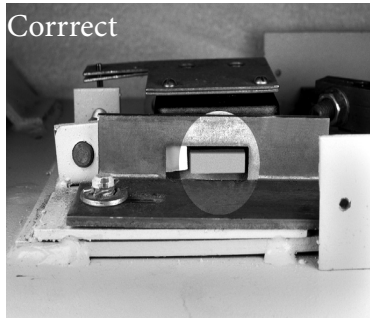

- B. If your safe incorporates a relock device, you will need to attach the plate that normally holds it in check to the lock body. This is usually done at the lock's cover screw locations. Remove the cover screws. **DO NOT REMOVE THE LOCK COVER**, as this will void the product warranty. Typically, the cover screws will be replaced with slightly longer 8-32 machine screws. Your replacement screws must engage the threaded holes in the lock body by at least four threads. Relock device designs vary from safe to safe. You must make sure the replacement cover screws hold the lock cover firmly against the lock body, and that the relock device plate holds the device securely in check. Otherwise, there is risk of a lockout. After the plate is installed, once again check to make sure wires and cables are secured so that they will not come into contact with moving boltwork or anything else that can damage them.

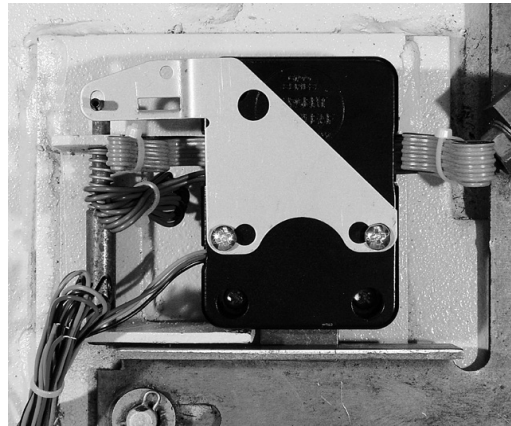

Keypad and Keypad Extension Installation with Escutcheon

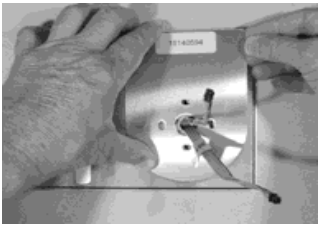

1. Clean the front surface of the safe door so the number plate will adhere. Remove the clear protective film from the front of the plate, and affix the included serial number label as shown. Next, remove the protective paper backing on the underside of the plate, then run both cables through the center hole of the plate. Place the plate on the front of the safe, carefully lining up the mounting screw holes in the safe door. The plate will stick in place when pressed against the door.

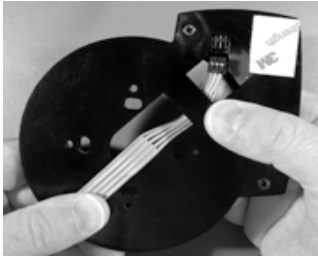

2. From the front of the safe, connect the five-conductor cable (the larger one) to the keypad extension base. The connector and receptacle are “keyed,” so the connector will only seat when oriented correctly. Route the cable as shown here. Make sure the connector is fully seated in the keypad extension receptacle. Note the self-adhesive pad to the right of the cable receptacle. Once the connector is plugged in, remove the protective backing from this pad. Pull all excess cable through the center opening to the front of the extension base. Then line up the base’s mounting screw holes with those in the door, and press the extension against the door. The extension can be mounted in four different orientations. Pick the one that best suits your particular application.



3. Place the keypad base over the keypad extension, pull all excess cable through the center hole (as shown), line up the keypad base mounting screw holes with those in the door, and use the included 8-32 (or M4) machine screws to securely fasten the mounting base to the door. It will also hold the keypad extension and number plate (if used) firmly in place. The raised, circular post near the edge of the base will be very near the bottom of the keypad. Use this feature as a reference to help you orient the base correctly before you fasten it into place.

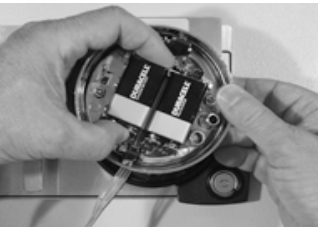

4. At the front of the safe, install a new 9- volt battery in each of the keypad’s two battery holders. Duracell® brand batteries are recommended. Support the top of each holder with a thumb or finger as each battery is inserted. This will help prevent bending or breaking the holder posts. The keypad cable connector is shaped so that it will fit into the keypad receptacle only when aligned correctly. Insert the connector into the receptacle in the underside of the keypad. If it does not seat easily, do not force it. This means you need to turn it 180° before attempting to insert it again.



5. Place the keypad over the base. Make sure the keypad cable is clear of the pad’s two spring clips as you push the keypad firmly onto the base. It should snap into place. If you need to remove the keypad, pull the bottom (area nearest the S&G logo) away from the mounting base first. Never allow the keypad to hang by the attached cable. The installation is complete, but do not close the safe door until successfully completing the following lock test.

The installation is complete, but do not close the safe door until successfully completing the following lock test.

Lock Test

The following check should be performed three times with the door remaining OPEN. At the keypad, enter 10 10 10 10 #. The lock will BEEP three times and its bolt will retract. Turn the safe handle to verify that the lock is unlocked. Turn the safe handle to the locked position. The green STATUS 1 LED on the keypad extension will light briefly. **The safe door should remain open for the three operational checks.** You can close the safe door and turn the handle to the locked position after the third operational check. The lock bolt will extend, and the lock will BEEP three times. In addition, the green STATUS 1 LED on the keypad extension will light briefly. Test the safe’s handle to make sure it is secure.



Keypad and Keypad Extension Installation



1. From the front of the safe, connect the five-conductor cable (the larger one) to the keypad extension base. The connector and receptacle are “keyed,” so the connector will only seat when oriented correctly. Route the cable as shown here. Make sure the connector is fully seated in the keypad extension receptacle. Note the self-adhesive pad to the right of the cable receptacle. Once the connector is plugged in, remove the protective backing from this pad. Pull all excess cable through the center opening to the front of the extension base. Then line up the base’s mounting screw holes with those in the door, and press the extension against the door.



2. Place the keypad base over the keypad extension, pull all excess cable through the center hole (as shown), line up the keypad base mounting screw holes with those in the door, and use the included 8-32 (or M4) machine screws to securely fasten the mounting base to the door. It will also hold the keypad extension and number plate (if used) firmly in place. The raised, circular post near the edge of the base will be very near the bottom of the keypad. Use this feature as a reference to help you orient the base correctly before you fasten it into place. The extension can be mounted in four different orientations. Pick the one that best suits your particular application.



3. At the front of the safe, install a new 9-volt battery in each of the keypad’s two battery holders. Duracell® brand batteries are recommended. Support the top of each holder with a thumb or finger as each battery is inserted. This will help prevent bending or breaking the holder posts.



4. The keypad cable connector is shaped so that it will fit into the keypad receptacle only when aligned correctly. Insert the connector into the receptacle in the underside of the keypad. If it does not seat easily, do not force it. This means you need to turn it 180° before attempting to insert it again.

5. Place the keypad over the base. Make sure the keypad cable is clear of the pad’s two spring clips as you push the keypad firmly onto the base. It should snap into place. If you need to remove the keypad, pull the bottom (area nearest the S&G logo) away from the mounting base first. Never allow the keypad to hang by the attached cable.

6. Attach the lock Serial number to the Keypad Extension plate.



The installation is complete, but do not close the safe door until successfully completing the following lock test.

Lock Test

The following check should be performed three times with the door remaining OPEN.

At the keypad, enter 10 10 10 10 #. The lock will BEEP three times and its bolt will retract. Turn the safe handle to verify that the lock is unlocked. Turn the safe handle to the locked position. The green STATUS 1 LED on the keypad extension will light briefly. The safe door should remain open for the three operational checks. You can close the safe door and turn the handle to the locked position after the third operational check. The lock bolt will extend, and the lock will BEEP three times. In addition, the green STATUS 1 LED on the keypad extension will light briefly. Test the safe’s handle to make sure it is securely